

16DI Module

for the MOSCAD-L RTU

The 16 Digital Input module is an accessory to the MOSCAD-L RTU that allows up to 16 wet or dry closures, from switches or relays in other on-site equipment, to be connected to the RTU. Examples include site or equipment door switches, centrifugal switches on motors, equipment malfunction switches, and tank float switches.

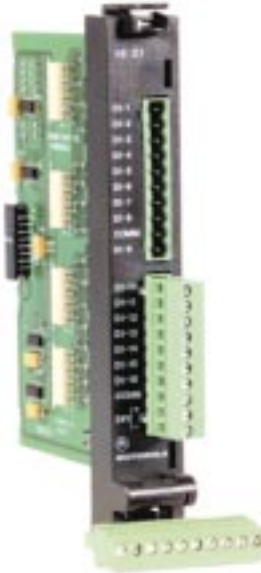

Features / Benefits

Data Input

Under the control of the defined Application Program, the CPU module will read the current instantaneous status of one or more of the 16 inputs. It will move that data from the 16DI module into the CPU module via the motherboard.

- ◆ *This data may then be used by the Application Program to perform the desired functions.*

Low-Speed Counter Inputs

Each of the 16 digital inputs may be used as low-speed counter inputs if desired. The totalizing will be done within the CPU module under Application control.

- ◆ *Any number of counter inputs are easily obtained.*

Wet or Dry Inputs

Each digital input accepts input currents from external 12 or 24 Vac/dc sensors. The module provides a floating 24 Vdc output to wet the contacts on dry-contact sensors.

- ◆ *A single module provides a universal interface to most of the sensors likely to be encountered.*

Time-Tagging

Any of the 16 digital inputs may be defined to tag the time of the input event with one millisecond accuracy.

- ◆ *This time may then be read and used in sequence-of-event actions, etc. or used later for historical reports.*

Optical Isolation

All inputs are protected by optical isolators on the module.

- ◆ *Surge Withstand Capability (SWC) conformance is assured for the safety of the equipment and technicians.*



MOTOROLA

16DI Module

for the MOSCAD-L RTU

Specifications

SPECIFICATIONS

Inputs:	Sixteen (16) inputs, 56 Vdc maximum
Input Frequency:	Without interrupt upon COS: 5 Hz maximum With interrupt upon COS: 50 Hz maximum
Input Signal:	On: $V_{in} > 9\text{ V}$ or $I_{in} > 1.0\text{ ma}$ Off: $V_{in} < 3\text{ V}$ or $I_{in} < 0.3\text{ ma}$
Filtering:	Software control of hardware filtering: 2-38 msec. Longer filtering within the application.
Interrupt upon COS:	Number of priorities = 255. Event time-tag resolution = 5 msec.
Isolation:	Per IEC 255-5: between user connection and logic = 2.5 kV; insulation resistance = 100 Mohm @ 500 V; insulation impulse = 5 kV
Protection:	Per ANSI/IEEE C37.90.1-1989: oscillatory wave = 2.5 kV; fast transient = 4 kV Per IEC 801-2: air discharge = 8 kV Per IEC 801-3: radiation immunity = 10 V/m Per IEC 801-4: fast transient = 500 V
Diagnostics:	LEDs on CPU module: 16 input status

Connections Chart	Term	Function	Term	Function	Term	Function	Term	Function
	1	In-1	6	In-6	11	In-10	16	In-15
	2	In-2	7	In-7	12	In-11	17	In-16
	3	In-3	8	In-8	13	In-12	18	com 9-16
	4	In-4	9	com 1-8	14	In-13	19	+24 Vdc
	5	In-5	10	In-9	15	In-14	20	-24 Vdc

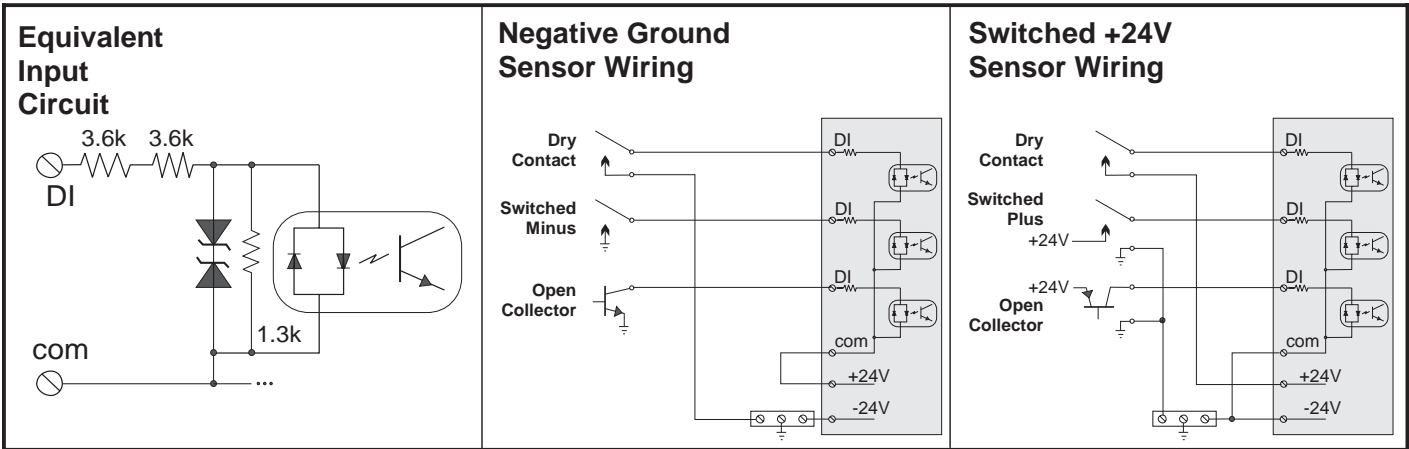

Support Services

Wherever Motorola sells, our product is backed by service. Our products are serviced throughout the world by a wide network of company or authorized independent distributor service organizations. Specifications subject to change without notice.



1301 E. Algonquin Road
Schaumburg, Illinois 60196
In the U.S. call: 1-800-247-2346
Outside the U.S. call: (708) 576-3107

©, and Motorola are trademarks of Motorola, Inc. ■ © 1994
Motorola, Inc. ■ Printed in U.S.A. ■ Produced
by Customer Communications. 36 USC 380
Motorola is an Equal Employment Opportunity/
Affirmative Action Employer